

Western Reitturnier



Eliesenhof Open

17. & 18. Juni 2017

Eliesenhof

Welzheim-Eckartsweiler

Zuschauer sind
herzlich willkommen!

DEUTSCHE
QUARTER
HORSE
ASSOCIATION

AMERICAN
QUARTER
HORSE
ASSOCIATION

Teilnehmer Eliesenhof Open

Rasseoffene Klassen

1 Gino	Debler; Lea	Iggingen
2 LH Jac Moreno	Goller; Roland	Pliezhausen
5 Narya Star	Grimm; Sina	Hardthausen A. K.
6 Kings Leap Year Boy	Schuller; Tamina	Schwaebisch Gmuend
7 CM Hollywood Gold	Friz; Maren	Goeppingen-Holzheim
8 Gun Socks Choice	Berger; Johanna	Allmersbach
9 Good Luck Bandit	Przemus; Eileen	Bierungen
10 HB Lenas Crazy King	Platzer; Tina	Pliezhausen
	Pfeiffer; Sonja	Reutlingen
11 Miss Peppy Remedy	Rau; Sophia	Kaisersbach
	Rau; Birgit	Kaisersbach
12 EHS Hannons Red Vintage	Rau; Sophia	Kaisersbach
13 Summer Sam Dunit	Rau; Sophia	Kaisersbach
14 Gimli	Wiedmann; Sandra	Wangen
17 Haidas Cutter Lynx	Turge; Doerte	Limeshain
21 Jumping Smart	Kurowski; Melanie	Auenwald
22 She Stepping Smart	Jaeger-Larsen; Britta	Berglen
23 First Dry Award	Posch; Michaela	Neuenstein
25 HW Roosters Angel	Bretzler; Mona	Wäschenbeuren
27 HQ Hot Commander	Schuller; Arwen	Aalen
28 Lonesome Anthony	Blumenstock; Christina	Neuenstein
31 Makin My Own Way	Reicherter; Sabrina	St. Johann
32 EH Jacs LittleBandit	Matjasic; Justin	Neuhausen
33 FS Hollywood Cowgirl	Daumueller; Denise	Wolfschlugen
37 Cry Me Cat	Widlicky; Philipp	Schorndorf
40 Red Chili Rooster	Hildenbrand; Catrin	Malsch

VRH Klassen

3 Brave Double Chex	Jung; Bernd H	Flieden
4 Us Hollywood Skeets	Schnepf; Frank	Gaggenau
17 Haidas Cutter Lynx	Turge; Doerte	Limeshain
18 Eyota	Koebel; Patrick	Lauterbourg
19 Pepito	Lorentz; Claude	Beinheim
20 Brady Smoke Jo	Lorentz; Julie	Betschdorf
24 Skips Hunting Hawk	Biesalski; Bettina	Willstaett
26 Silent Little Lynx	Siegle; Rolf	Grafenau
29 Tivios Poco Booker	Weber; Andre	Gaggenau
30 Pocos Rebel Son	Weber; Karina	Gaggenau
34 HS Flying Colors	Kaufmann; Nicole	Ahorn-Schillingstadt
38 LM Docs Cayenne	Maier; Miriam	Gernsbach
39 Amazing Sugar Star	Hildenbrand; Thomas	Malsch
41 Cromed Gold	Spitzenberger; Meiko	Plienzhausen
42 Jokers Luna	Hoffmann; Lucca Josephina	Moessingen

Zeitplan Eliesenhof Open

Samstag, 17. Juni 2017

08:00	50	DY120 RO-Jugend Showmanship At Halter / Entries: 3
	51	DN120 RO-Einsteiger Showmanship At Halter / Entries: 6
	52	DA120 RO-Amateur Showmanship At Halter / Entries: 3
	53	D360 RO-Open Western Riding / Entries: 1
09:00	54	DY380 RO-Jugend Trail / Entries: 5
	55	DN380 RO-Einsteiger Trail / Entries: 8
	73	DN381 RO-Einsteiger Walk-Trot-Trail / Entries: 2
	150	S008 Trail In Hand / Entries: 1
	56	DA380 RO-Amateur Trail / Entries: 3
	57	D380 RO-Open Trail / Entries: 2
11:00	59	DN420 RO-Einsteiger Western Pleasure / Entries: 3
	60	DA420 RO-Amateur Western Pleasure / Entries: 1
	61	D420 RO-Open Western Pleasure / Entries: 1
	74	DN421 RO-Einsteiger Walk Trot Pleasure / Entries: 2
13:00	62	DY430 RO-Jugend Ranch Riding / Entries: 5
	63	DN430 RO-Einsteiger Ranch Riding / Entries: 7
	64	DA430 RO-Amateur Ranch Riding / Entries: 4
	65	D430 RO-Open Ranch Riding / Entries: 3
14:00	66	DY400 RO-Jugend Western Horsemanship / Entries: 4
	67	DN400 RO-Einsteiger Western Horsemanship / Entries: 5
	68	DA400 RO-Amateur Western Horsemanship / Entries: 4
	78	DN401 RO-Einsteiger Walk Trot Horsemanship / Entries: 3
15:00	69	DY340 RO-Jugend Reining / Entries: 4
	70	DN340 RO-Einsteiger Reining / Entries: 4
	71	DA340 RO-Amateur Reining / Entries: 3
	72	D340 RO-Open Reining / Entries: 2
16:30	2	162 Sen Working Cow Horse / Entries: 1
	4	360 Einsteiger Working Cow Horse / Entries: 1

Sonntag, 18 Juni 2017

08:00	12	181 VRH Ranch Trail Open/Amateur/Einsteiger
10:30	11	180 VRH Ranch Riding Open/Amateur/Einsteiger
13:00	13	182 RO-VRH Ranch Cutting Open/Amateur/Einsteiger
14:00	15	184 RO-VRH Ranch Reining Open/Amateur/Einsteiger
15:30	14	183 RO-VRH Ranch Cow Horse Open/Amateur/Einsteiger
16:30	16	188 RO-VRH Ranch Conformation Open/Amateur/Einsteiger

Eliesenhof Open

Showmanship at Halter (RO Einsteiger / Jugend)

Show Date: 17./18. Juni 2017

w w w . H o r s e S h o w P a t t e r n s . c o m

w w w . H o r s e S h o w P a t t e r n s . c o m

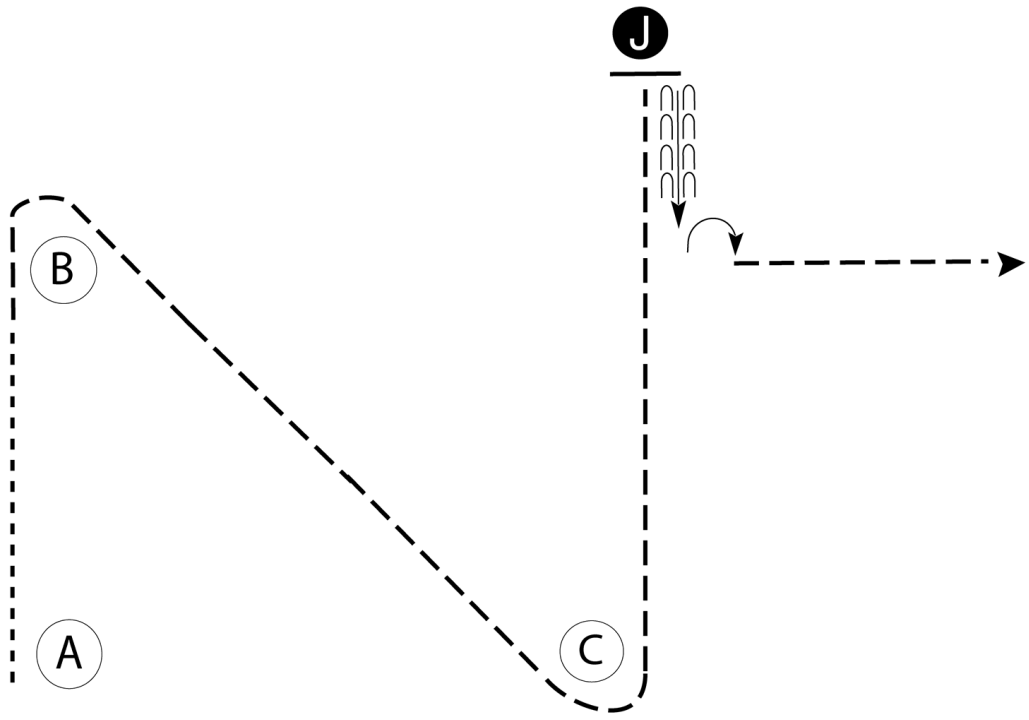

Be ready at A.

1. Walk to B.
2. Trot around B and C and straight to judge.
3. Stop and set up for inspection.
4. When dismissed, back one horse length.
5. Perform a 90 degree turn.
6. Trot straight away to finish.

Walk	-----
Trot	—————
Back	← ↔ ↔
Marker	ⓑ
Judge	ⓙ

[S/1-22]

Pattern Provided by:
Michaela Kayser

Eliesenhof Open

Showmanship at Halter (RO Amateur)

Show Date: 17./18. Juni 2017

w w w . H o r s e S h o w P a t t e r n s . c o m

w w w . H o r s e S h o w P a t t e r n s . c o m

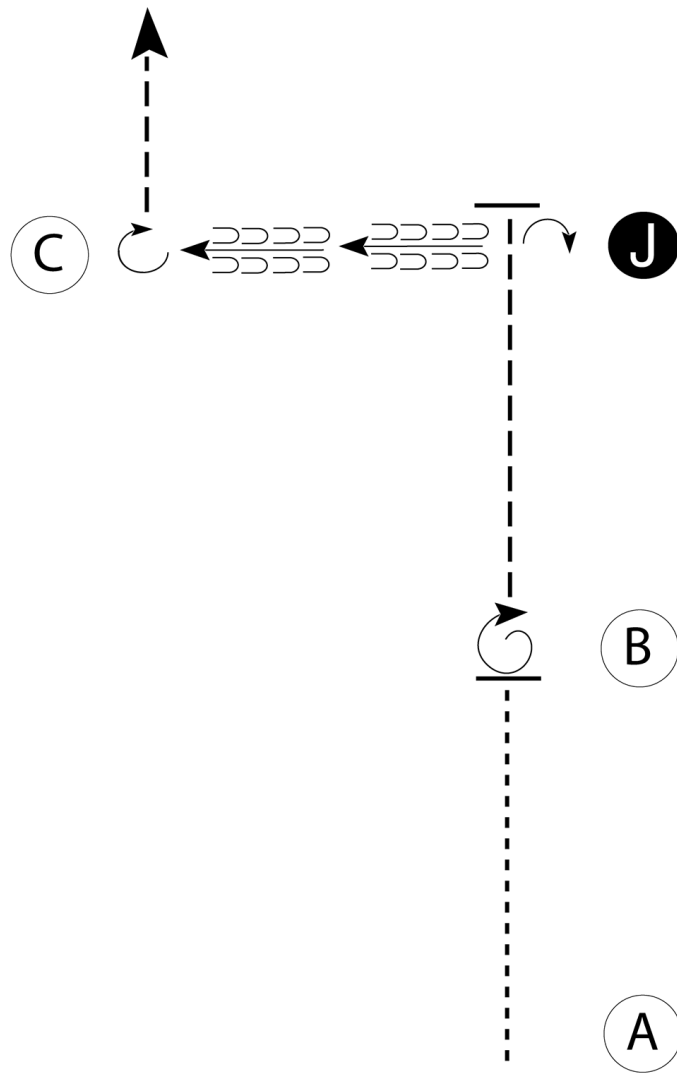

Be ready at A.

1. Walk A to B.
2. Stop at B and perform a 360 degree turn.
3. Trot until even with Judge.
4. Stop and perform a 90 degree turn; set up for inspection.
5. When dismissed, back to C.
6. Perform a 270 degree turn and trot straight away.

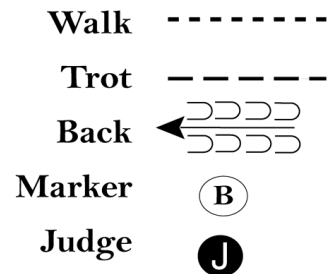

Follow the instructions of your ring steward.

[S/2-4]

Pattern Provided by:

Michaela Kayser

Eliesenhof Open

Western Horsemanship (RO Einsteiger / Jugend)

Show Date: 17./18. Juni 2017

www.HorseShowPatterns.com

www.HorseShowPatterns.com

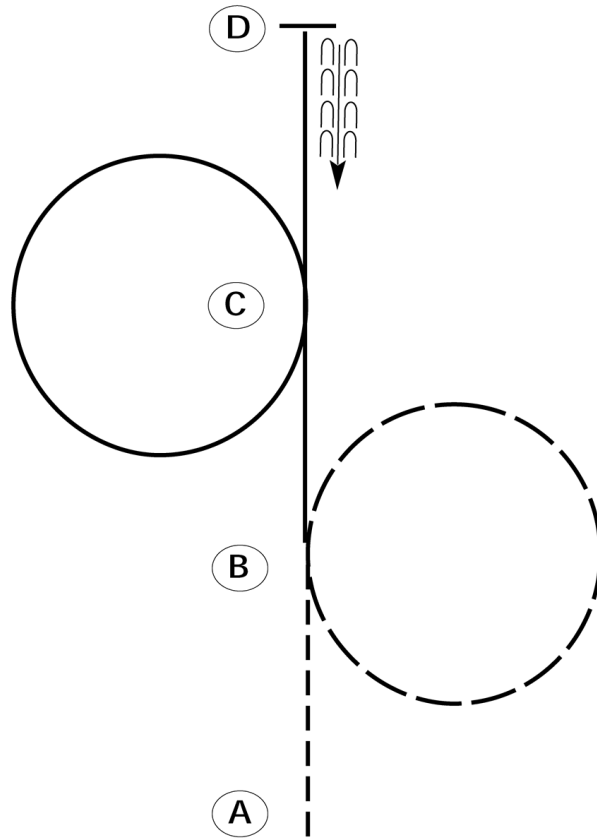

Be ready at A.

1. Jog from A to B.
2. Extend the jog in a circle to the right at B.
3. Lope on the left lead to C and circle to the left.
4. Continue to lope to D.
5. Stop and D and back one horse length.

Retire to the rail or line up at a jog.

Walk	-----
Jog	-----
Extended Jog	-----
Lope	—————
Leg Yield	
Lead Change	—/—
Back	←←←←← ←←←←←
Marker	⊙ B
Sidepass	←-----→

[WH/2-24]

Pattern Provided by:
Michaela Kayser

Eliesenhof Open

Western Horsemanship (RO Amateur)

Show Date: 17./18. Juni 2017

w w w . H o r s e S h o w P a t t e r n s . c o m

w w w . H o r s e S h o w P a t t e r n s . c o m

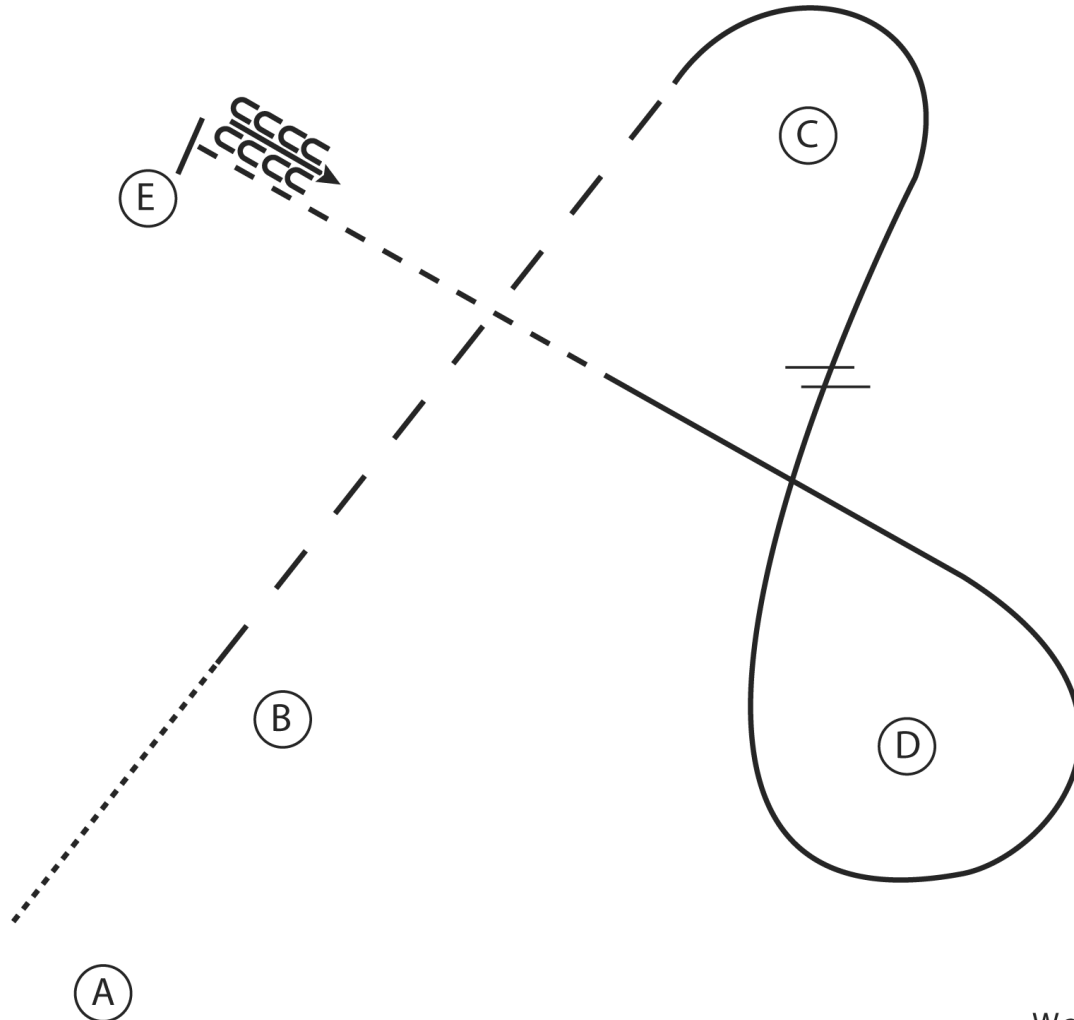

1. Walk A to B
2. At B extend the jog to C
3. At C lope a circle around C on the right lead
4. Between C and D perform a simple lead change
5. Lope a circle around D
6. Break to the jog when between D and E
7. At E stop and back 4 steps

Walk
Jog	-----
Extended Jog	-----
Lope	—————
Leg Yield	
Lead Change	↘
Back	←←←←
Marker	⊙ (B)
Sidepass	←←←←

[WH/2-11]

Pattern Provided by:
Michaela Kayser

Eliesenhof Open

Western Horsemanship (RO Einsteiger Walk / Trot)

Show Date: 17./18. Juni 2017

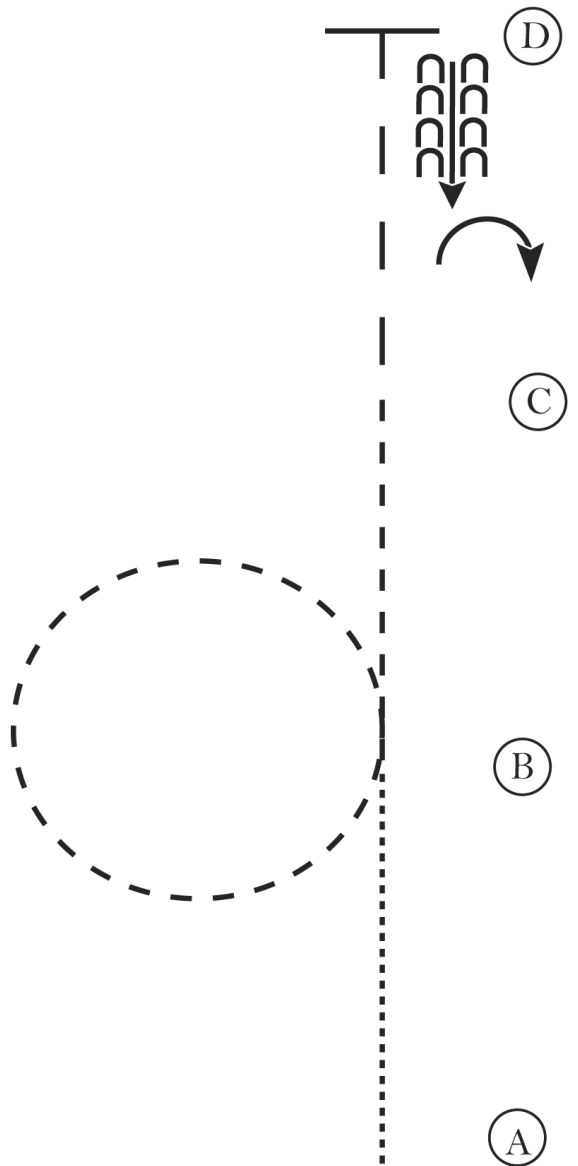

1. Walk A to B.
2. At B jog.
3. Jog a circle at B and continue to C.
4. At C extend the jog to D.
5. At D stop and back 4 steps.
6. Turn 90 degrees to the right.

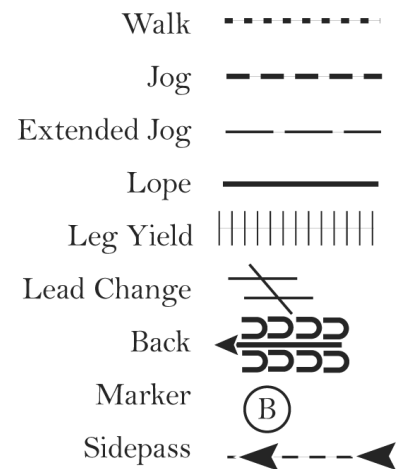

[WH/WT-11]

Pattern Provided by:
Michaela Kayser

Eliesenhof Open

Reining (RO Open / Amateur)

Show Date: 17./18. Juni 2017

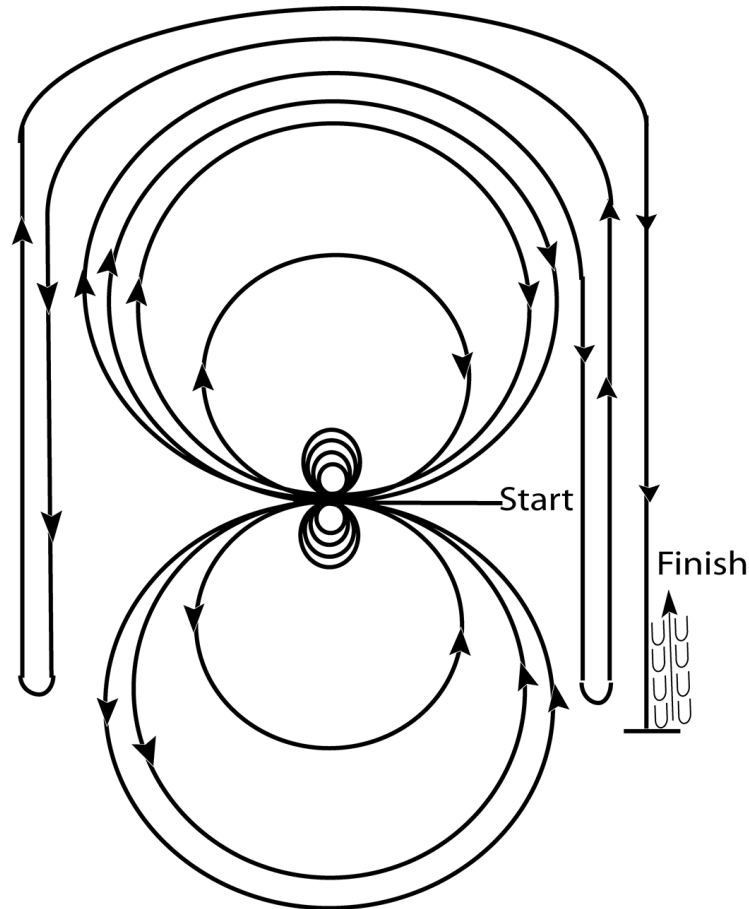

Horses must walk or stop prior to starting pattern. Beginning at the center of the arena facing the left wall or fence.

1. Complete four spins to the left.
 2. Complete four spins to the right. Hesitate.
 3. Beginning on the right lead, complete three circles to the right: the first circle large and fast; the second circle small and slow; the third circle large and fast. Change leads at the center of the arena.
 4. Complete three circles to the left: the first circle large and fast; the second circle small and slow; the third circle large and fast. Change leads at the center of the arena.
 5. Begin a large fast circle to the right but do not close this circle. Run straight down the right side of the arena past the center marker and do a left rollback at least twenty feet (6.09m) from the wall or fence – no hesitation.
 6. Continue back around the previous circle but do not close this circle. Run down the left side of the arena past the center marker and do a right rollback at least twenty feet (6.09m) from the wall or fence – no hesitation.
 7. Continue back around the previous circle but do not close this circle. Run down the right side of the arena past the center marker and do a sliding stop at least twenty feet (6.09m) from the wall or fence. Back up at least ten feet (3m). Hesitate to demonstrate completion of the pattern.
- Rider may drop bridle to the designated judge.

[R/AQHAP-8]

Pattern Provided by:

Michaela Kayser

Eliesenhof Open

Reining (RO Einsteiger / Jugend)

Show Date: 17./18. Juni 2017

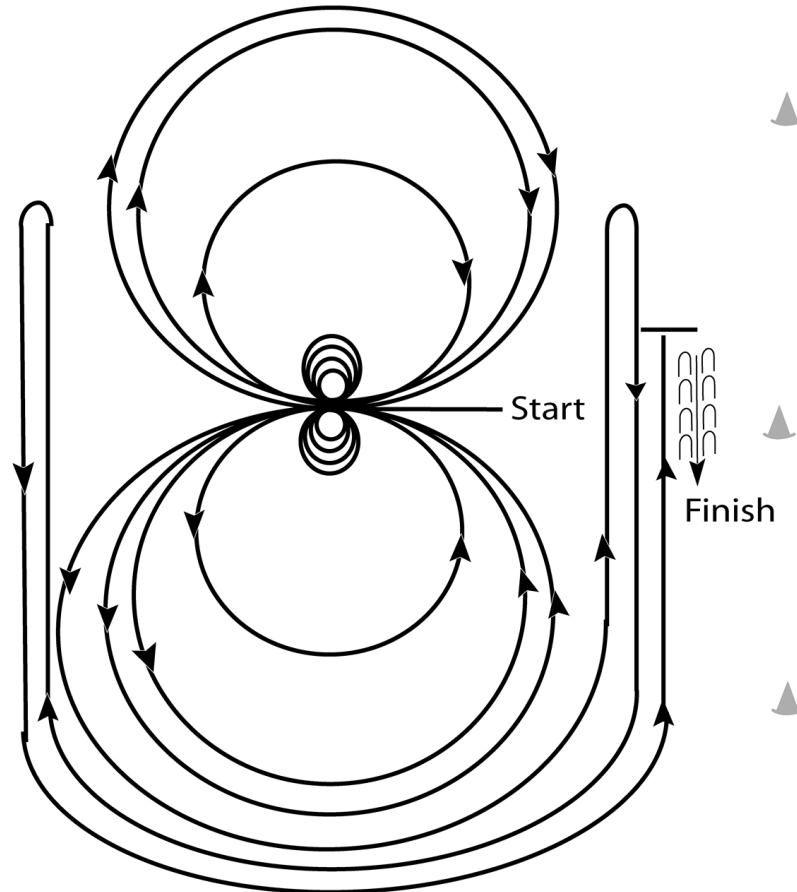

Horse must walk or stop prior to starting pattern. Beginning at the center of the arena facing the left wall or fence.

1. Complete four spins to the right.
 2. Complete four spins to the left. Hesitate.
 3. Beginning on the left lead, complete three circles to the left: the first two circles large and fast; the third circle small and slow. Change leads at the center of the arena.
 4. Complete three circles to the right: the first two circles large and fast; the third circle small and slow. Change leads at the center of the arena.
 5. Begin a large, fast circle to the left but do not close this circle. Run up the right side of the arena past the center marker and do a right rollback at least twenty feet (6.09m) from the wall or fence – no hesitation.
 6. Continue back around previous circle but do not close this circle. Run up the left side of the arena past the center marker and do a left rollback at least twenty feet (6.09m) from the wall or fence – no hesitation.
 7. Continue back around previous circle but do not close this circle. Run up the right side of the arena past the center marker and do a sliding stop at least twenty feet (6.09m) from the wall or fence. Back up at least ten feet (3m). Hesitate to demonstrate the completion of the pattern.
- Rider may drop bridle to the designated judge.

[R/AQHAP-6]

Pattern Provided by:

Michaela Kayser

Eliesenhof Open

Western Riding (RO Open)

Show Date: 17./18. Juni 2017

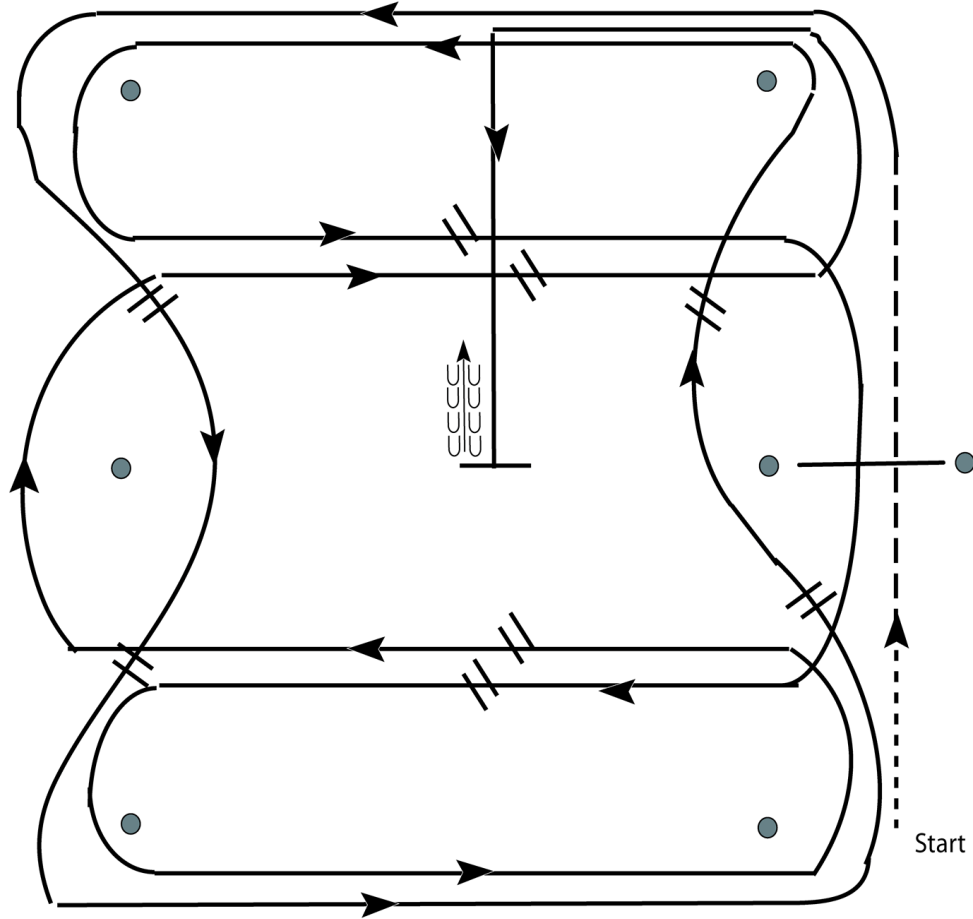

1. Walk, transition to jog, jog over log.
2. Transition to the lope, on the left lead.
3. First line change.
4. Second line change.
5. Third line change.
6. Fourth line change.
7. First crossing change.
8. Lope over the log.
9. Second crossing change.
10. Third crossing change.
11. Fourth crossing change.
12. Lope, stop and back.

[WR/OP-5]

Pattern Provided by:
Michaela Kayser

Eliesenhof Open

Ranch Riding (RO Open / Amateur)

Show Date: 17./18. Juni 2017

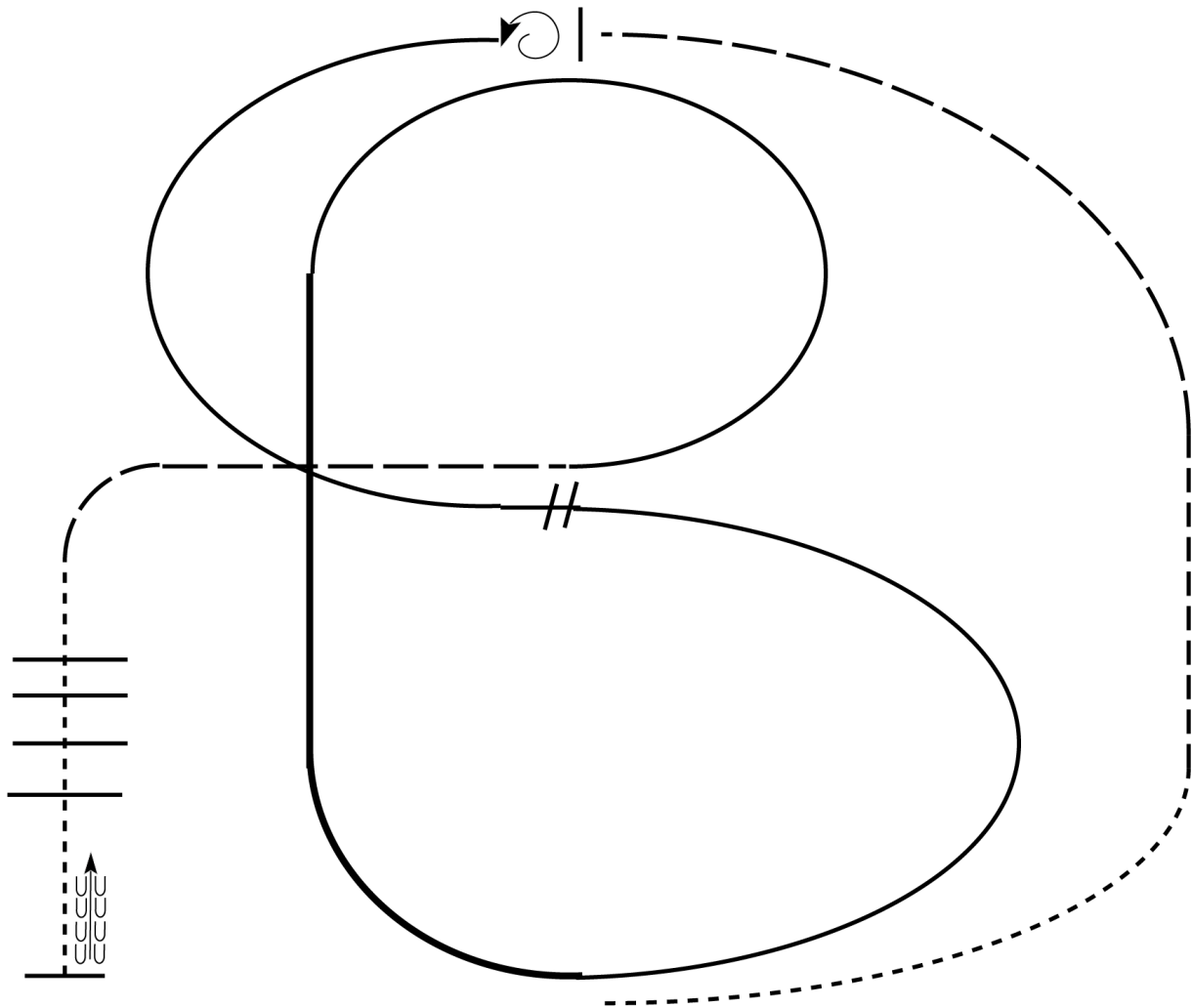

1. Walk
2. Trot
3. Extend the trot, at the top of the arena, stop
4. 360 degree turn to the left
5. Left lead 1/2 circle, lope to the center
6. Change leads (simple or flying)
7. Right lead 1/2 circle
8. Extended lope up the long side of arena (right lead)
9. Collect back to a lope around the top of the arena and back to center
10. Break down to an extended trot
11. Walk over poles.
12. Stop and back

Walk	-----
Jog	- - - - -
Extended Jog	-----
Lope	
Lead Change	///
Back	←
Marker	(B)

[RR/1]

Pattern Provided by:
Michaela Kayser

RO Ranch Riding Jugend + Einsteiger

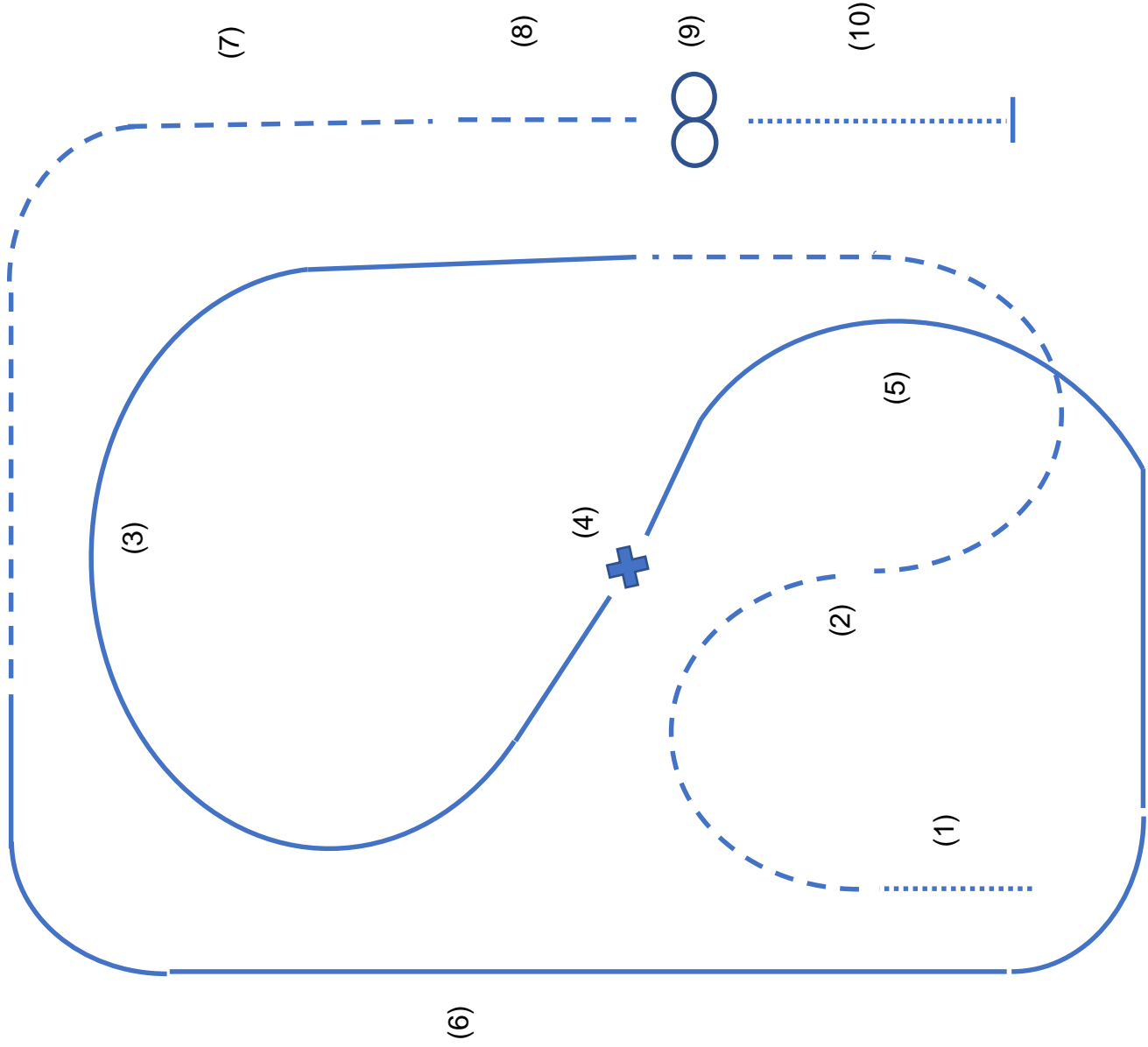

- (1) Schritt
- (2) Trab Serpentine
- (3) Linksgalopp
- (4) Galoppwechsel (einfach o. fliegend)
- (5) Rechtsgalopp
- (6) verstärkter Galopp
- (7) verstärkter Trab
- (8) Trab
- (9) 360 Grad in jede Richtung
- (10) Schritt, Stop, Rückwärts

RO Trail Open / Amateur

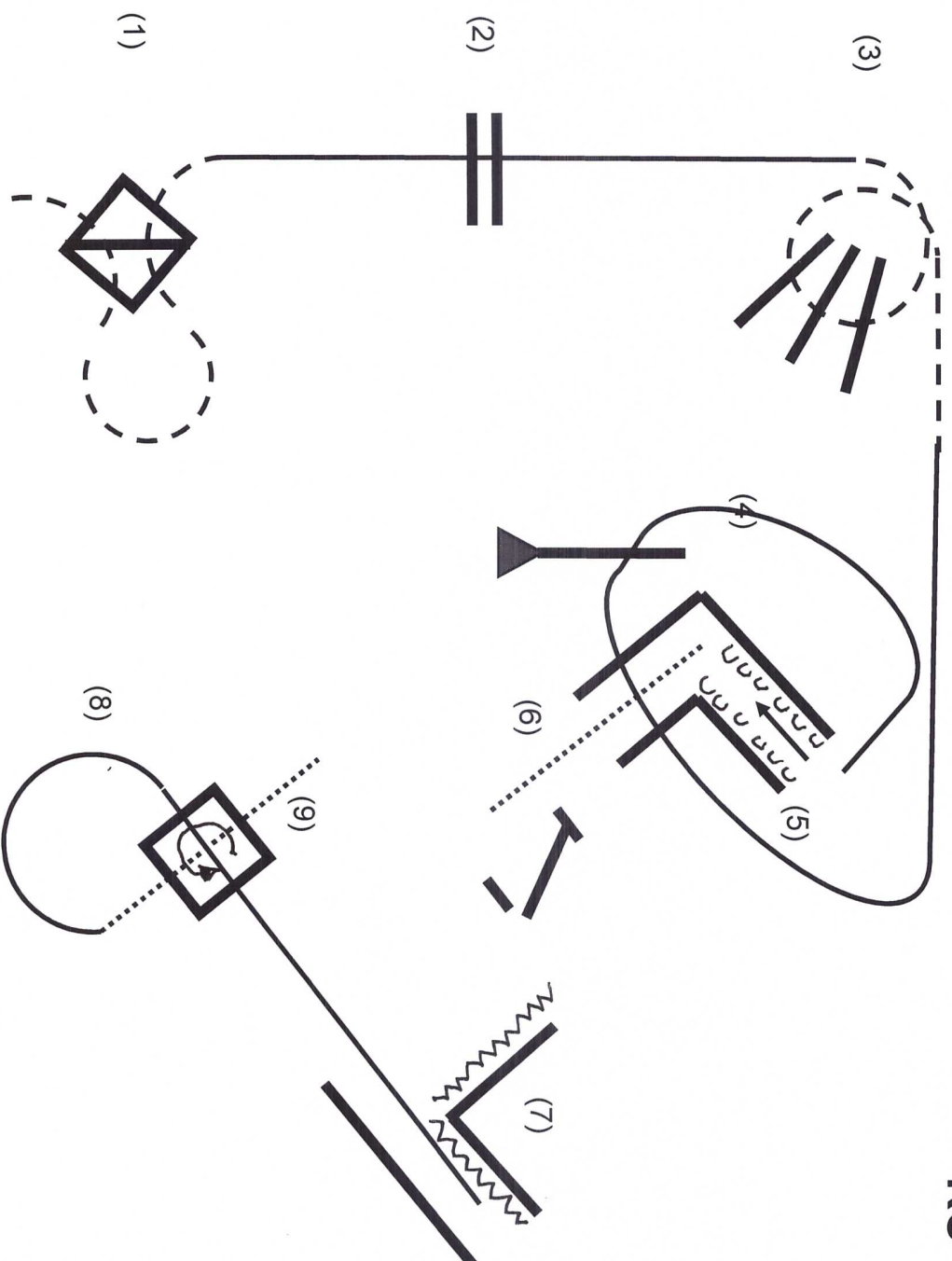

- (1) Trab Serpentine
- (2) Galoppstangen (Rechtsgalopp)
- (3) Trabstangen
- (4) Rechtsgalopp
- (5) Seitwärts
- (6) Schritt / Tor
- (7) Rückwärts
- (8) Linksgalopp
- (9) Schritt, 360 Grad links, Schritt

RO Trail Jugend / Einsteiger

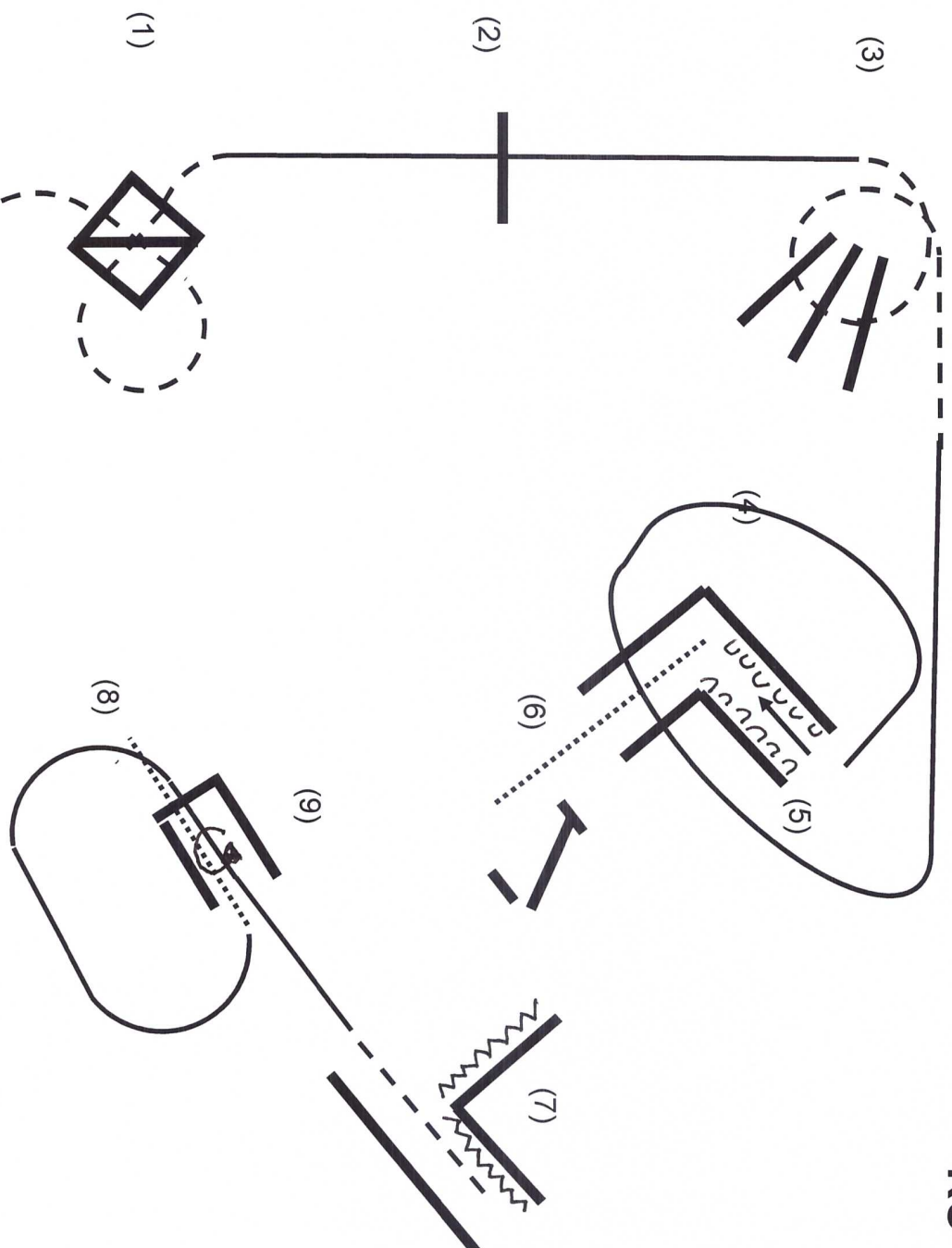

- (1) Trabstangen
- (2) Rechtsgalopp / Stange
- (3) Trabstangen
- (4) Rechtsgalopp / Stange
- (5) Seitwärts
- (6) Schritt und Tor
- (7) Rückwärts
- (8) Trab / Linksgalopp
- (9) Schritt, 360 Grad links, Schritt

Trail in Hand + Walk / Trot

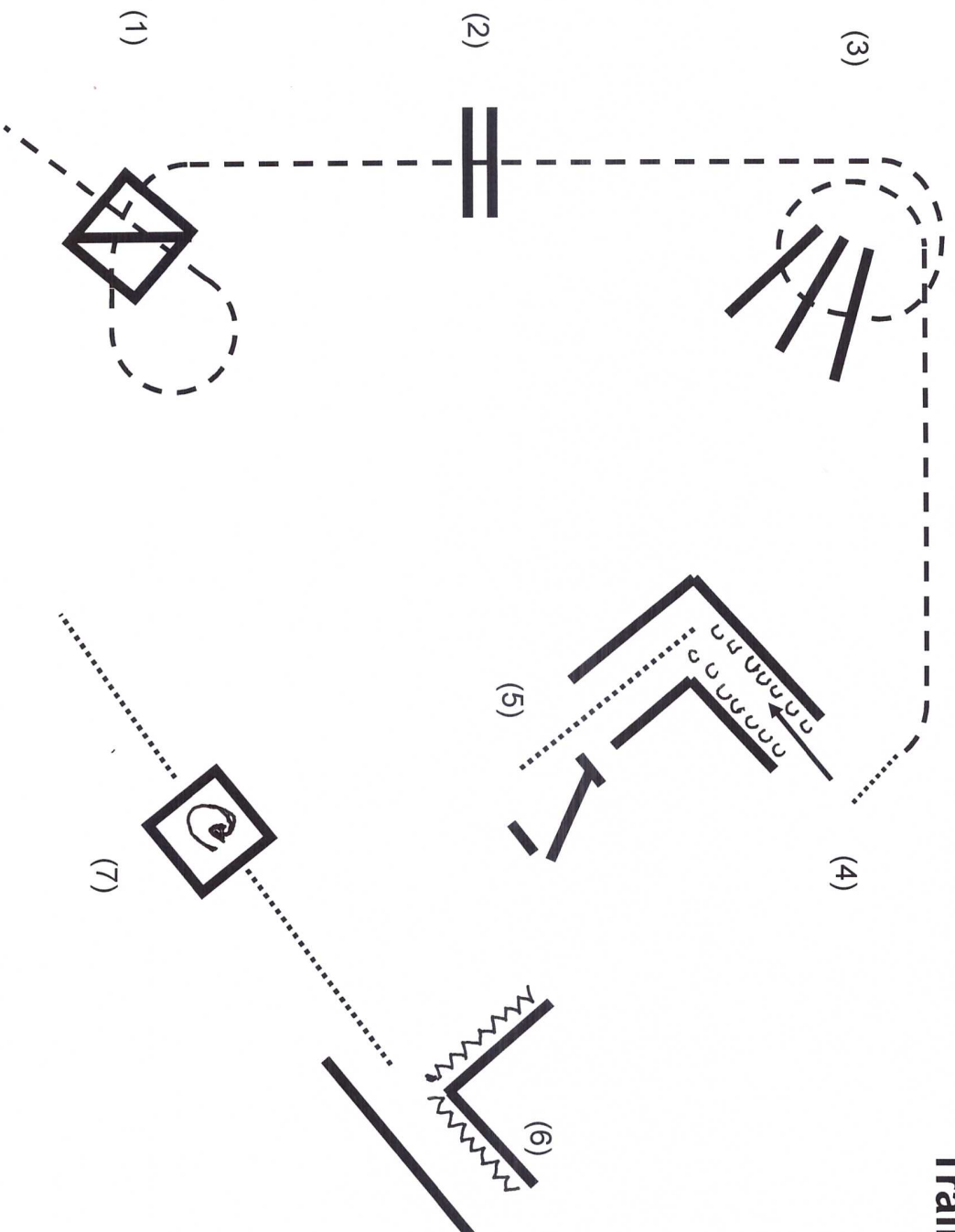

- (1) Trabstangen
- (2) Trabstangen
- (3) Trabrolle / Schritt
- (4) Seitwärts
- (5) Schritt / Tor
- (6) Rückwärts
- (7) Schrittstangen / 360 Grad rechts

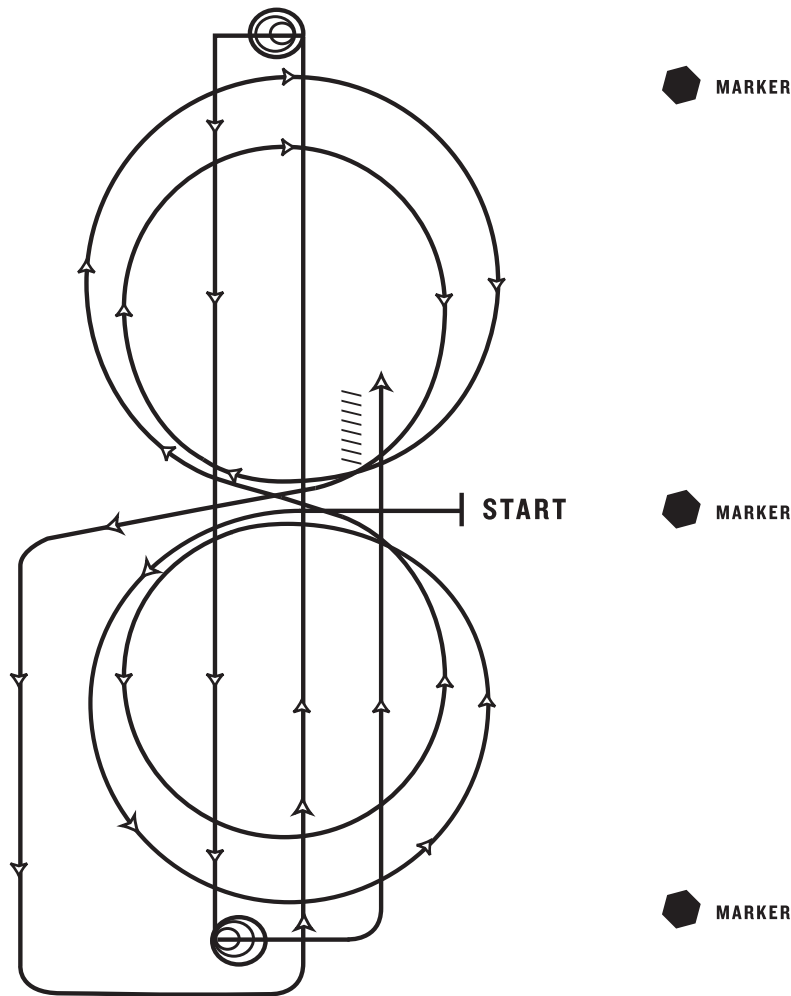

Trot to center of arena, stop. Start pattern facing towards judge

- | | |
|---|--|
| <ol style="list-style-type: none"> 1. Beginning on the left lead, complete 2 circles to the left; the first circle large and fast, the second circle small and slow. Change leads at the center of the arena. 2. Complete 2 circles to the right; the first circle large and fast, the second circle small and slow. Change leads at the center of arena. 3. Continue around end of arena without breaking gait or changing leads, run down center of arena past end marker, and execute a square sliding stop. 4. Complete 3 1/2 spins to the left. 5. Run down center of arena past end maker, and execute a square sliding stop. 6. Complete 3 1/2 spins to the right. 7. Run down center of arena past center marker, and execute a square sliding stop. 8. Back up at least 10 feet. 9. Hesitate to complete pattern. | <p>Pattern II</p> <ol style="list-style-type: none"> 1. Left circles 2. Right circles 3. Stop 4. 3 1/2 left spins 5. Stop 6. 3 1/2 right spins 7. Stop and back up |
|---|--|

This pattern may be used as a lope-in pattern; refer to SHW505.2.

Ranch Trail Open / Amateur

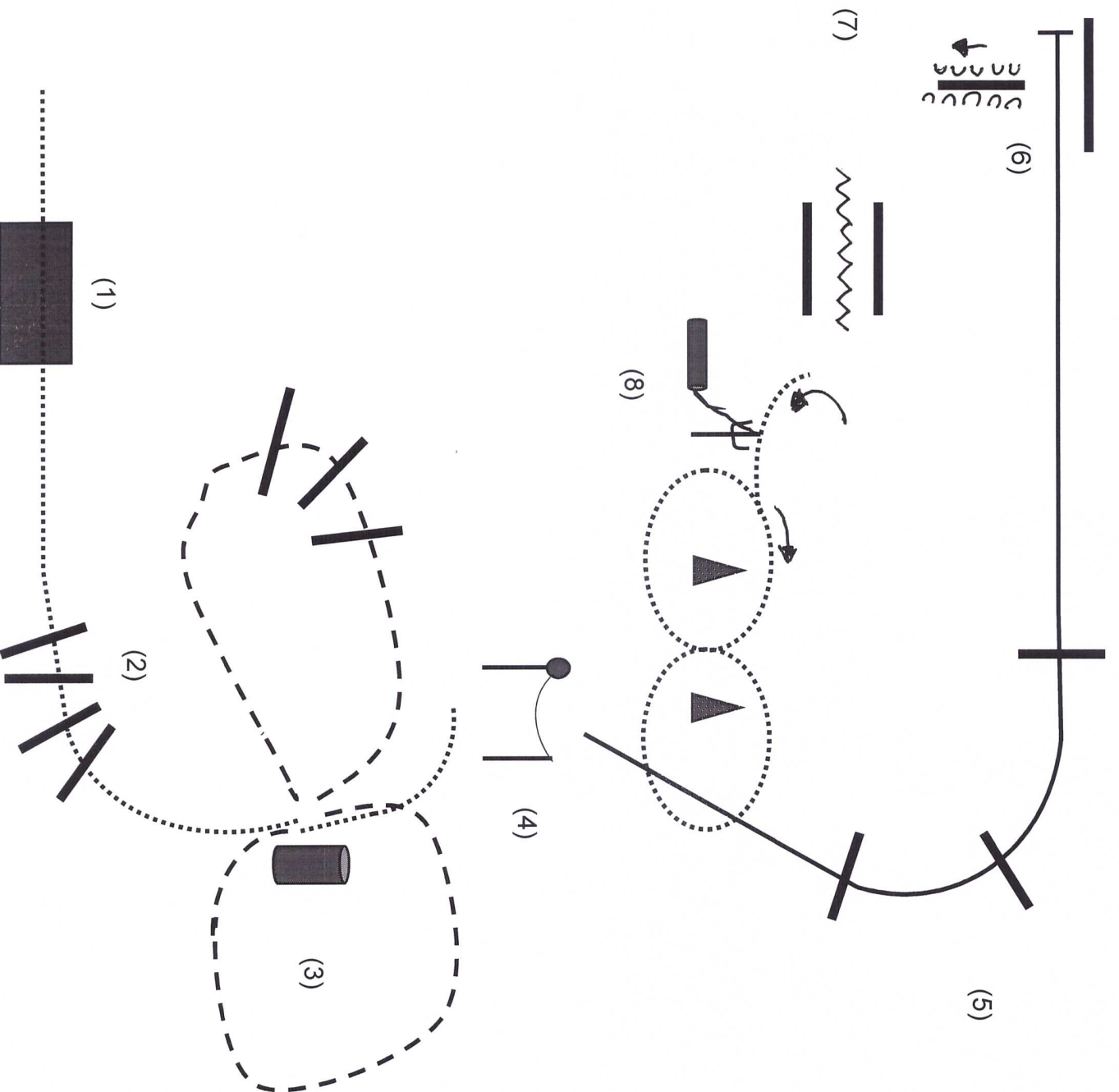

- (1) Brücke
- (2) Schrittstangen
- (3) Gegenstand aufnehmen, Trab 8, Gegenstand ablegen
- (4) Tor, rechte Hand
- (5) Linksgalopp über Stangen
- (6) Seitwärts
- (7) Rückwärts
- (8) Stamm ziehen 8

Ranch Trail Einsteiger

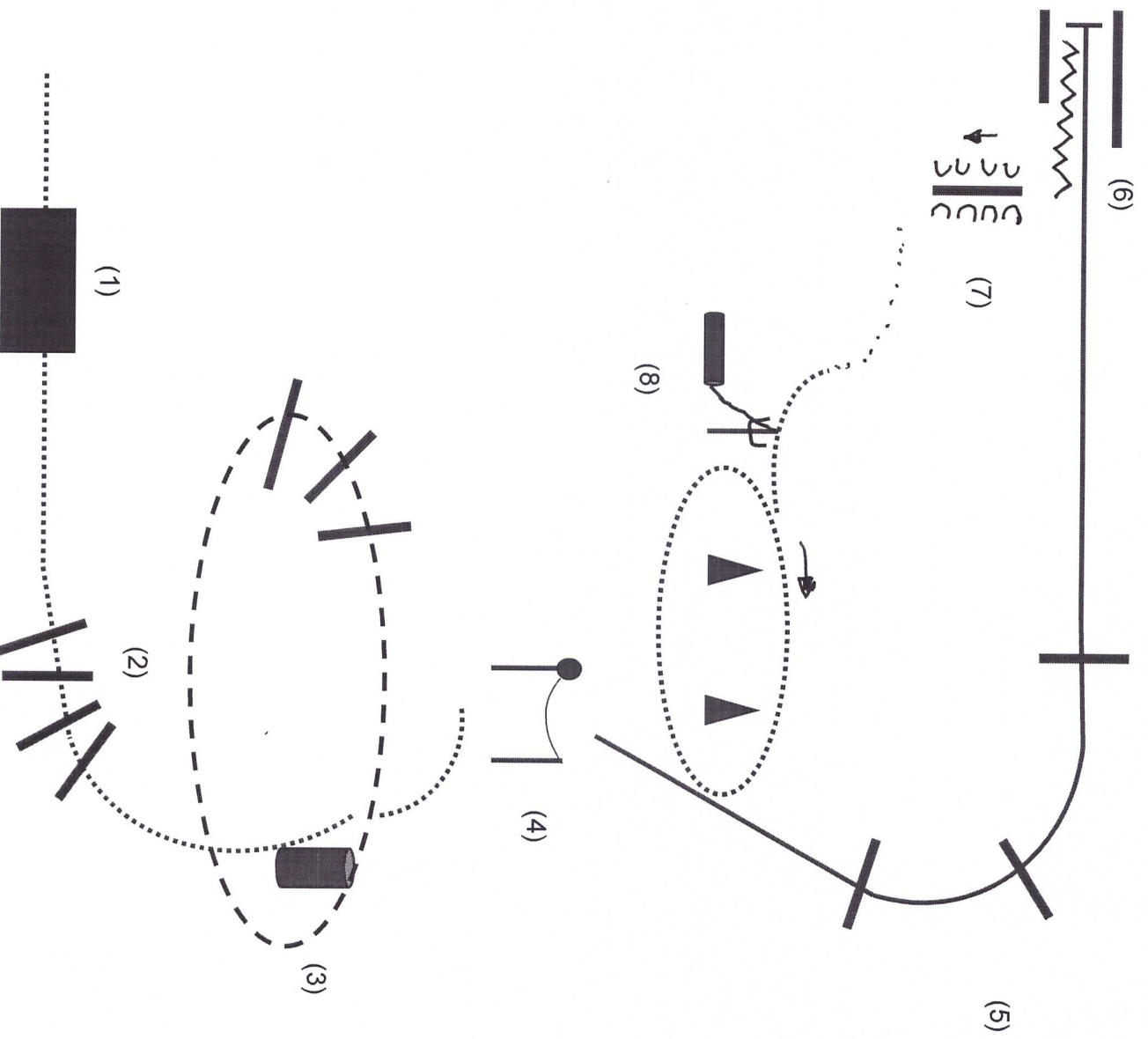

- (1) Brücke
- (2) Schrittstangen
- (3) Gegenstand aufnehmen, Trab,
Gegenstand ablegen
- (4) Tor, rechte Hand
- (5) Linksgalopp über Stangen
- (6) Rückwärts
- (7) Seitwärts
- (8) Stamm ziehen

VRH Ranch Reining Pattern I

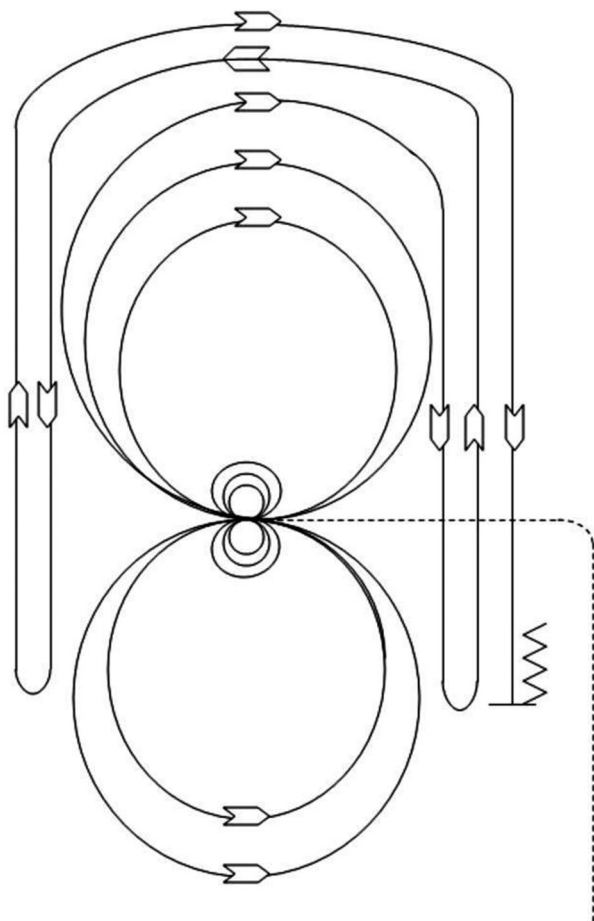

Mandatory Markers:

The judge shall indicate with markers on arena fence the center of the pattern.

Ride pattern as follows:

1. Trot to center of arena and stop.
2. Complete three spins in each direction
3. Begin on right lead and lope two large fast circles to the right, change leads.
4. Lope two large fast circles to the left, change leads.
5. Begin a large circle to the right but do not close this circle. Run down the right side of the arena past the center marker and do a left roll back at least 20 feet from the wall or fence, no hesitation.
6. Continue back around the previous circle but do not close this circle. Run down the left side of the arena past the center marker and do a right roll back at least 20 feet from the wall or fence, no hesitation.
7. Continue back around previous circle but do not close this circle. Run down the right side of the arena past the center marker and do a sliding stop at least 20 feet from the wall or fence. Back up at least 10 feet. Hesitate to show completion of pattern.

VRH Ranch Riding Alle

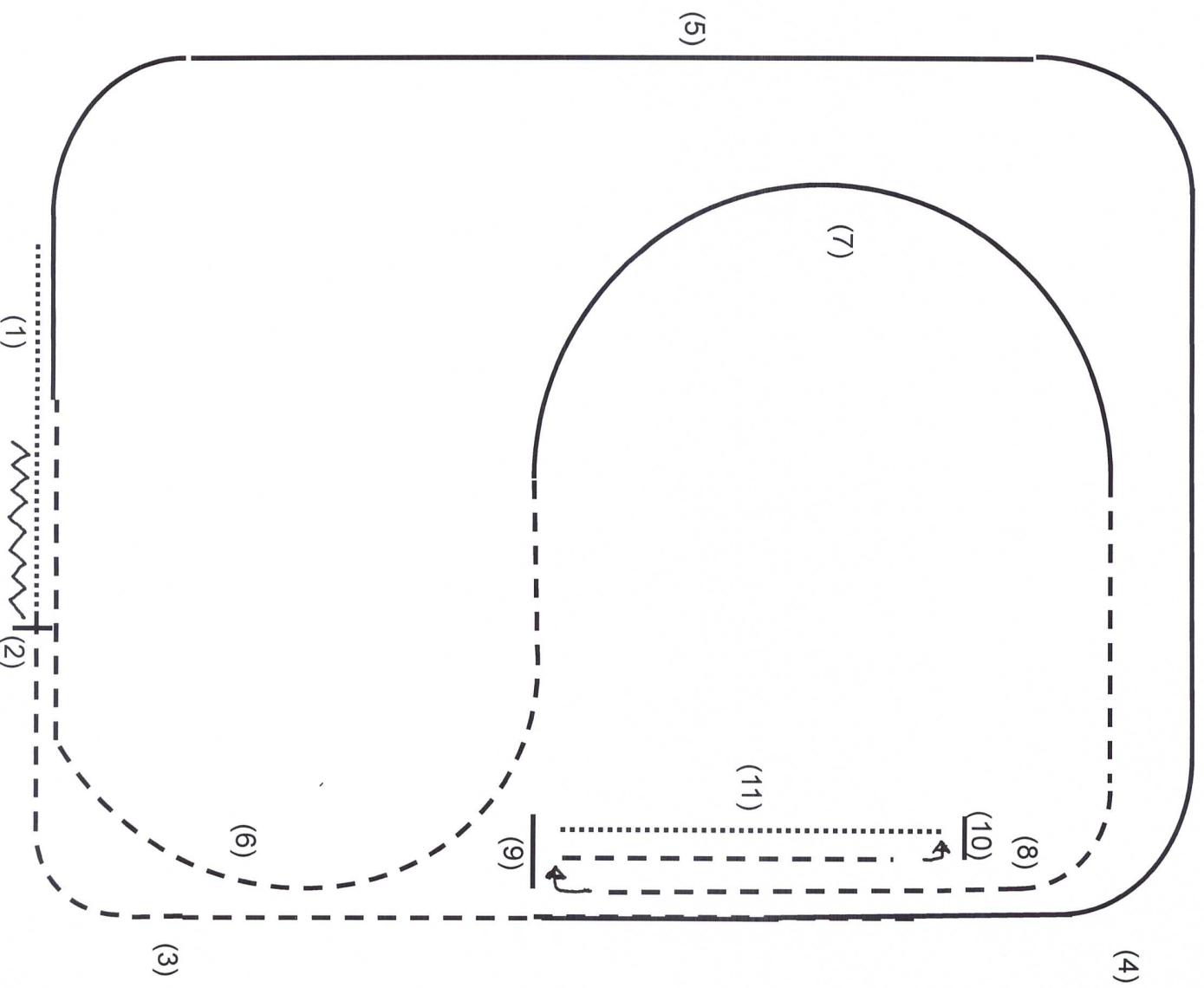

- (1) Schritt
- (2) Stopp + Rückwärts
- (3) Trab
- (4) Linksgalopp
- (5) Verstärkter Galopp
- (6) verstärkter Trab
- (7) Rechtsgalopp
- (8) Trab
- (9) Anhalten + 180 Grad rechts
- (10) Trab + 180 Grad links
- (11) Schritt